

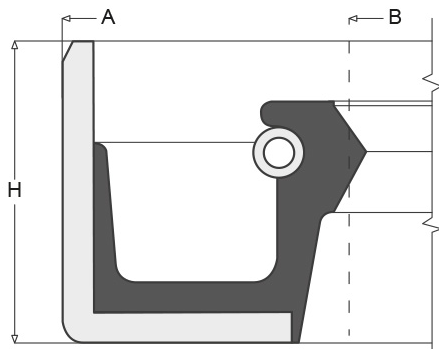

ROTARY SHAFT OIL SEAL: M

CODE 000814



DIMENSIONS		
B	17,00	
A	28,00	
H	7,00	
TOLERANCE DIN3760 - 1996 (all dimensions in mm)		
EXTERNAL DIAMETER		
External diameter	Tolerance	
D	External metal	External rubber
until 50	+0.08 +0.20	+0.15 +0.30
from 50 to 80	+0.09 +0.23	+0.20 +0.35
from 80 to 120	+0.10 +0.25	+0.20 +0.35
from 120 to 180	+0.12 +0.28	+0.25 +0.45
from 180 to 300	+0.15 +0.35	+0.25 +0.45
from 300 to 440	+0.20 +0.45	+0.30 +0.55
over 440	Contact our Technical Department	
THICKNESS OR HEIGHT		
until 10	+/- 0.20	
over 10	+/- 0.30	
DESCRIPTION		
Oil seal in rubber-to-metal produced according to DIN 3760 Norm. The outer diameter is bare metal. The sealing lip is obtained by cutting process to avoid imperfection. Energized with a garter spring.		
PRESSURE: Up to 0.5 BAR (0.05 MPa)		
USE: Radial Sealing		
OUTSIDE Ø: Metal		
CONSTRUCTION: Metal casing + Sealing lip + Garter spring		
APPLICATIONS		
General Industry;		

The present drawing is property of F.Ili Paris S.r.l. a socio unico, who owns all rights on it. Full or partial reproductions are forbidden unless authorized by written permission.
 The information given in this drawing are to be considered confidential.
 The drawing in this page is for information only. Please contact our offices for an official drawing with all notes, dimensions and tolerances not present in this document.

F.Ili Paris S.r.l. a socio unico

fpparis.com

via Marconi 142/144, 24060 Castelli Calepio (BG) ITALY
 ☎ +39 035 442 5511 | 📠 +39 035 442 5478 | ✉ info@fpparis.com

15-01-2025